

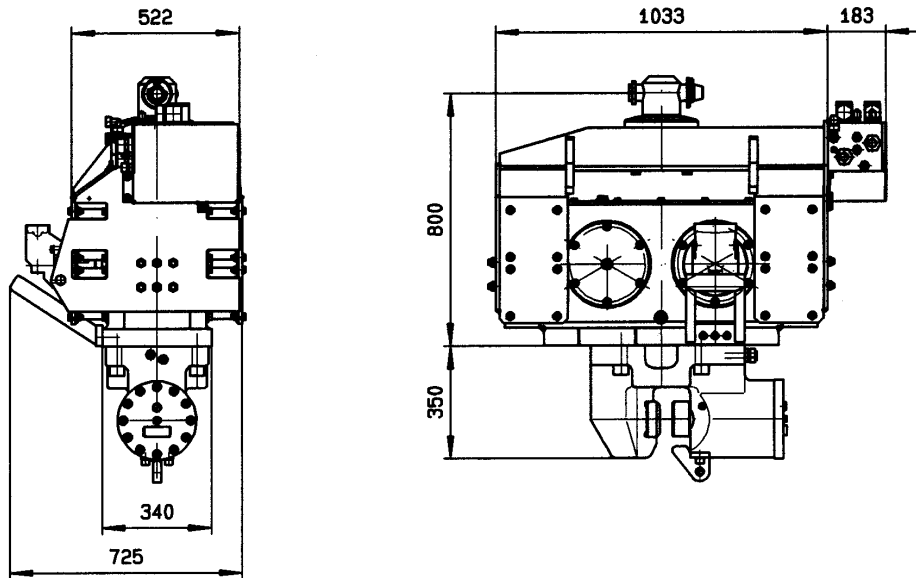

Müller-Vibrator MS-7 HFB	TA 0526/1 Dat.: 24.09.2001 Name: Honig
---	---



TECHNISCHE DATEN / TECHNICAL DATA
Vibrator

Fliehkraft max.	/ centrifugal force max.	kN	604
Exzentermoment	/ eccentric moment	kgm	7
Drehzahl max.	/ speed max.	min ⁻¹	2800
Zugkraft max.	/ line pull max.	kN	150
Druckkraft max.	/ push down max.	kN	80
Gewicht *	/ weight *	kg	1300
Gewicht (dynamisch) *	/ weight (dynamic) *	kg	950
Hydraulik:			
Schluckvolumen	/ flow rate	l/min	224
Betriebsdruck max.	/ working pressure max.	bar	350

*mit Spannzanze *with clamping device

Subject to Technical modifications

Distributed in Australia & New Zealand by **ThyssenKrupp Steelcom**
A company of ThyssenKrupp Services

PO Box 840 North Sydney
NSW 2059 Australia
T: +61 2 9954 9166
Sales +61 2 4966 0688
F: +61 2 9955 4298
enquiries@steelcom.com.au
www.steelcom.com.au

PO Box 51254 Pakuranga
Auckland 2140 New Zealand
T: +64 9 576 3977
F: +64 9 576 3978
afenn@steelcomnz.co.nz
www.steelcomnz.co.nz



ThyssenKrupp

Herstellung und Verkauf von
MULLER
 Ramm- u. Ziehetechnik